



FND type

LCD type

IR controller  
(Standard)



Smart phone application  
(Bluetooth Option)



TF-100



TF-400

ZigBee Controller  
(Option)

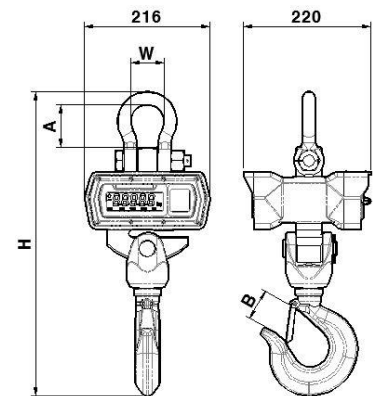

## FEATURE

- ◆ Detachable lithium polymer battery pack
- ◆ Lightweight & easy to carrying
- ◆ Swivel hook
- ◆ Bluetooth, ZigBee wireless communication (Option)

| MODEL         | DIMENSION |     |    |    |
|---------------|-----------|-----|----|----|
|               | H         | A   | W  | B  |
| TCS - 1T / L  | 407       | 62  | 50 | 25 |
| TCS - 3T / L  | 518       | 73  | 57 | 34 |
| TCS - 5T / L  | 525       | 73  | 57 | 40 |
| TCS - 10T / L | 679       | 101 | 83 | 55 |

| MODEL             | TCS-1T   | TCS-3T  | TCS-5T  | TCS-10T  | TCS-1TL                      | TCS-3TL | TCS-5TL | TCS-10TL |
|-------------------|--|---------|---------|----------|------------------------------|---------|---------|----------|
| Capacity          | 1,000kg  | 3,000kg | 5,000kg | 10,000kg | 1,000kg                      | 3,000kg | 5,000kg | 10,000kg |
| Division          | 0.5kg  | 1kg     | 2kg     | 5kg      | 0.5kg                        | 1kg     | 2kg     | 5kg      |
| Max. Tare Weight  | 1,000kg  | 3,000kg | 5,000kg | 10,000kg | 1,000kg                      | 3,000kg | 5,000kg | 10,000kg |
| Product weight    | 9kg  | 15kg    | 16.5kg  | 27kg     | 9kg                          | 15kg    | 16.5kg  | 27kg     |
| Display           | 5digit, 21mm FND   |         |         |          | 6 digit, 20mm LCD            |         |         |          |
| Operating time    | Approx.90hr  |         |         |          | Approx.200hr (Backlight off) |         |         |          |
| Battery           | Lithium polymer 7.4V   |         |         |          | Lithium polymer 3.7V         |         |         |          |
| Charging adaptor  | DC 12V, 1A SMPS  |         |         |          | DC 5V, 1A SMPS               |         |         |          |
| Temperature range | -10℃ ~ 40℃   |         |         |          |                              |         |         |          |
| Keypad            | Power , Zero , Tare , *  |         |         |          |                              |         |         |          |
| Display lamp      | Low Battery, Zero, Tare, Hold, Stable                                      |         |         |          |                              |         |         |          |
| Parts             | Charging adaptor, Lithium polymer battery pack, Infrared remote controller |         |         |          |                              |         |         |          |