

FEATURE

- ◆ Water Proof : IP-66
- ◆ Low platform height : 34mm
- ◆ Wireless Communication by using ZigBee
- ◆ Easy to change battery pack(Lithium Polymer Battery)
- ◆ Data communication with TXI-500F
- ◆ Possible to print out results by using TXI-500F

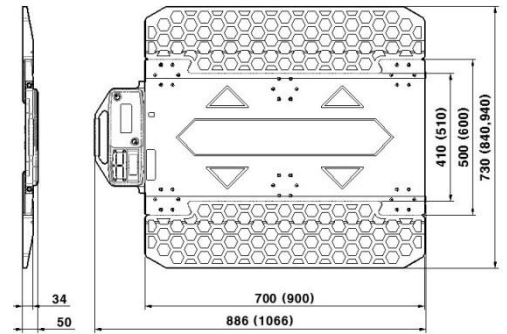

MODEL	TXD-710F	TXD-715F	TXD-910F	TXD-915F	TXD-920F
Capacity	10,000kg	15,000kg	10,000kg	15,000kg	20,000kg
Division	10kg	20kg	10kg	20kg	20kg
Product dimensions (W x L x H)	886 x 730 x 50 (mm)		1066 x 840 x 50 (mm)		1066 x 940 x 50 (mm)
Platform dimensions (W x L x H)	700 x 500 x 34 (mm)		900 x 500 x 34 (mm)		900 x 600 x 34 (mm)
Product weight	Approx. 23.5kg		Approx. 28.0kg		Approx. 40kg
Ramp weight	Approx. 1.6kg x 2PCS		Approx. 2.9kg x 2PCS		
Accuracy	0.1%				
Safety Overload	150% of capacity				
Power	3.7VDC Lithium Polymer Battery				
Operating time	Approx. 55hr				
Key	ON/OFF , ZERO , SUM , BACK LIGHT				
Display	5digit LCD (height 15mm) back light				
Parts	Rechargeable adaptor, Lithium polymer battery pack 1ea				
Temperature range	-10℃ ~ 40℃				