

QHC Counting Scales

General Specifications

- Display 20mm digit LCD display, with white LED backlight
- Capacities 3kg~30kg
- Pan size 230 x 300mm
- Keyboard 20 keys (Membrane keyboard)
- Housing ABS plastic
- Max. Divisions 3,000e; 2 x 3,000e; 30,000d; 60,000d
- ADC update $\leq 1/10$ second
- Operating Temp. $-10^{\circ}\text{C} \sim +40^{\circ}\text{C}$
- Power AC adapter (12V/500mA), internal rechargeable battery (6V/4Ah)
- Gross weight 5.1kg



- Responds quickly with accurate weights
- Battery provides up to 70 hours of continuous use (without backlight)
- OIML approval from NMI (approval no.T7305)
- Counting method: 1. Sample 2. Enter unit weight
- Applications: 1. Piece counting 2. Preset tare 3. Quantity alarm
4. Accumulation 5. 10 product memory function
- Optional RS-232 interface to connect to computer or printer
- Optional initial-verification



QHC Counting Scales

Model Name	Capacity	Readability	Division	Approx. weight	Approval
QHC-3K	3kg	0.1g	30,000d	5.1kg	CE
QHC-6K	6kg	0.2g	30,000d	5.1kg	CE
QHC-15K	15kg	0.5g	30,000d	5.1kg	CE
QHC-30K	30kg	1g	30,000d	5.1kg	CE
QHC+-3K	3kg	0.05g	60,000d	5.1kg	CE
QHC+-6K	6kg	0.1g	60,000d	5.1kg	CE
QHC+-15K	15kg	0.2g	60,000d	5.1kg	CE
QHC+-30K	30kg	0.5g	60,000d	5.1kg	CE
QHC-3K-M	3kg	1g	3,000e	5.1kg	CE, OIML
QHC-6K-M	6kg	2g	3,000e	5.1kg	CE, OIML
QHC-15K-M	15kg	5g	3,000e	5.1kg	CE, OIML
QHC-30K-M	30kg	10g	3,000e	5.1kg	CE, OIML
QHC-6K-MR	6kg	1g/2g	2 x 3,000e	5.1kg	CE, OIML
QHC-15K-MR	15kg	2g/5g	2 x 3,000e	5.1kg	CE, OIML
QHC-30K-MR	30kg	5g/10g	2 x 3,000e	5.1kg	CE, OIML

Options



Dimensions(mm)

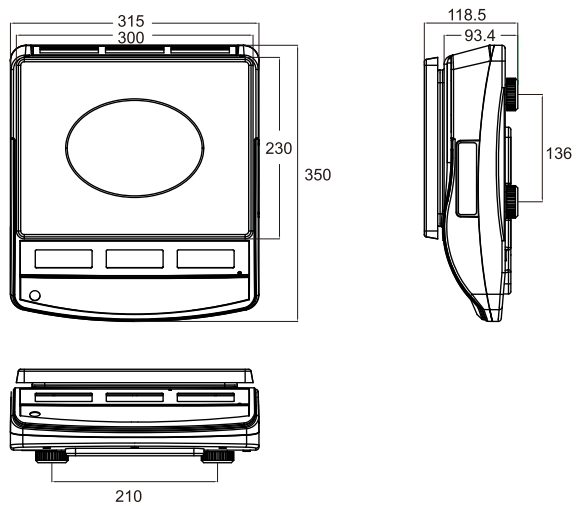

Print formats

