



TD-2300F / TD-3000F(Optional)



TF-100



TF-400

ZigBee Controller (Option)

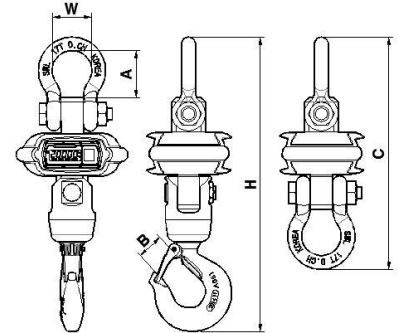

FEATURE

- ◆ Water Proof : IP-65
- ◆ Wireless communication by using Zigbee (Standard)
- ◆ Easy to exchange battery pack
- ◆ Interface with Wireless Remote Display and Controller

MODEL	DIMMENSION				
	H	A	W	B	C
TCU -1T	407	62	50	25	-
TCU -3T	503	73	57	34	-
TCU-5T	525	73	57	40	-
TCU-10T	679	101	83	53	-
TCU-15T	826	127	98	64	623
TCU-20T	1031	151	128	75	745

MODEL	TCU-10T	TCU-15T	TCU-20T
Capacity	10,000kg	15,000kg	20,000kg
Division	5kg	5kg	10kg
Max. Tare Weight	10,000kg	15,000kg	20,000kg
Product weight	26.6kg	40kg	54kg
Operating time	Approx. 90hr		
Battery	Lithium Polymer Battery 3.7V		
Battery Spec.	3.7V 4000mA (Size:68x125x12)		
Temperature range	-10℃ ~ 40℃		
Frequency	2.4 GHz		
Frequency range	100m(Open Space)		
RF Output Power	Max. 4dBm		
Keypad	Power & Zero key (1key)		
Display lamp	Low Battery (Green), Power On (Red)		
Parts	Charging Adaptor, Lithium Polymer Battery Pack		
Charging Adaptor	DC 5V, 1A		